



Type L-852A-D Dualite Bidirectional Taxiway Light Fixtures

Document No. 96A0149

Issued: January 29, 1993

Rev. E: May 16, 2001

Manufactured to FAA Specification
AC 150/5345-46B

Siemens Airfield Solutions, Inc.

P.O. Box 30829
977 Gahanna Parkway
Columbus, OH 43230

Tel: (614) 861-1304
Fax: (614) 864-2069

Copyright © 2001 by Siemens Airfield Solutions, Incorporated. All rights reserved.

Siemens Airfield Solutions

*The innovative
approach*

Record of Changes

Page	Rev	Description	EC No.	Checked	Approved	Date
	B	Added metric units.		EP	WT	
	C	Added shallow base information.		EP	WT	
All	D	Added 30 W L-852A, B, C. Reformatted manual.	3355	JG	WT	3/26/98
All	E	Changed to new title page. Changed ADB to Siemens Airfield Solutions.	00696	JG	WT	5/16/01

Table of Contents

Record of Changes.....	ii
Table of Contents.....	iii
Warranties.....	v
1. Safety	1
Safety Symbols.....	1
Qualified Personnel.....	2
Intended Use	2
Installation	3
Operation	3
Action in the Event of a System or Component Malfunction.....	4
Maintenance and Repair.....	4
2. Description	5
Optical Assembly.....	6
Optional Film Disc Cutout	8
L-852A-D Light Fixture: Required Equipment.....	8
Specifications.....	9
Lamps.....	9
Isolation Transformers.....	9
Rated Lamp Life	9
Filter Colors	9
Light Beam.....	9
Mounting.....	10
Environmental Operating Conditions.....	10
Dimensions.....	10
Weight.....	10
3. Installation	11
Introduction	11
Unpacking	11
Input Requirement Summary.....	11
Installation Procedure	11
Pavement Recess and Wireways Preparation	11
Installation on L-868B Base.....	13
Installation on Siemens Airfield Solutions Shallow Base.....	14
4. Maintenance	17
Maintenance Schedule	17
Maintenance Procedures.....	17
Replacing Lamp.....	18
Cleaning Light Channel and Prism	18
Retorquing Mounting Bolts.....	20
Removing L-868B Base Water	20

5. Troubleshooting.....	21
6. Repair.....	23
Replacing Film Disc Cutout Assembly	23
Replacing Lamp.....	25
Replacing Prism.....	26
7. Parts	27
Using the Illustrated Parts List	27
L-852A-D Light Fixture Part Numbering System	27
L-852A-D Light Fixture Parts List	29
Recommended Spare Parts List	32

List of Figures

Figure 1. L-852A-D Dualite Light Fixture	6
Figure 2. Optical Assembly.....	7
Figure 3. Preparing Pavement Recess and Wireways	12
Figure 4. Alignment Jig	15
Figure 5. Cutaway View of Optical Assembly	19
Figure 6. Replacing Film Disc Cutout Assembly.....	24
Figure 7. L-852A-D Light Fixture Part Numbers	28
Figure 8. L-852A-D Light Fixture with Shallow Base (Part 1 of 2)	30
Figure 8. L-852A-D Light Fixture with Shallow Base (Part 2 of 2)	31

List of Tables

Table 1. L-852 Series Light Fixtures.....	5
Table 2. Required Equipment Supplied	8
Table 3. Required Equipment Not Supplied	8
Table 4. Required Isolation Transformers	9
Table 5. Connectors Supplied	10
Table 6. L-852A-D Light Fixture Maintenance	17

Warranties

Products of Siemens Airfield Solutions manufacture are guaranteed against mechanical, electrical, and physical defects (excluding lamps) for a period of one year from the date of installation or a maximum of two years from the date of shipment and are guaranteed to be merchantable and fit for the ordinary purposes for which such products are made.

Siemens Airfield Solutions will correct by repair or replacement, at its option, equipment or parts which fail because of mechanical, electrical or physical defects, provided that the goods have been properly handled and stored prior to installation, properly installed and properly operated after installation, and provided further that Buyer gives Siemens Airfield Solutions written notice of such defects after delivery of the goods to Buyer.

Siemens Airfield Solutions reserves the right to examine goods upon which a claim is made. Said goods must be presented in the same condition as when the defect therein was discovered. Siemens Airfield Solutions further reserves the right to require the return of such goods to establish any claim.

Siemens Airfield Solutions's obligation under this guarantee is limited to making repair or replacement within a reasonable time after receipt of such written notice and does not include any other costs such as the cost of removal of defective part, installation of repaired product, labor or consequential damages of any kind, the exclusive remedy being to require such new parts to be furnished.

Siemens Airfield Solutions's liability under no circumstances will exceed the contract price of goods claimed to be defective. Any returns under this guarantee are to be on a transportation charges prepaid basis. For products not manufactured by, but sold by Siemens Airfield Solutions, warranty is limited to that extended by the original manufacturer.

This is Siemens Airfield Solutions's sole guarantee and warranty with respect to the goods; there are no express warranties or warranties of fitness for any particular purpose or any implied warranties of fitness for any particular purpose or any implied warranties other than those made expressly herein. All such warranties being expressly disclaimed.

Disclaimers

This manual could contain technical inaccuracies or typographical errors. Siemens Airfield Solutions reserves the right to revise this manual from time to time in the contents thereof without obligation of Siemens Airfield Solutions to notify any person of such revision or change.

Details and values given in this manual are average values and have been compiled with care. They are not binding, however, and Siemens Airfield Solutions disclaims any liability for damages or detriments suffered as a result of reliance on the information given herein or the use of products, processes or equipment to which this manual refers. No warranty is made that the use of the information or of the products, processes or equipment to which this manual refers will not infringe any third party's patents or rights. The information given does not release the buyer from making their own experiments and tests.

Type L-850A Dualite Bidirectional Runway Light Fixture

1. Safety

This section contains general safety instructions for using your Siemens Airfield Solutions equipment. Some safety instructions may not apply to the equipment in this manual. Task- and equipment-specific warnings are included in other sections of this manual where appropriate. Note all warnings and follow all instructions carefully. Failure to do so may result in personal injury, death, or property damage.

To use this equipment safely,

- refer to the FAA Advisory Circular AC 150/5340-26, *Maintenance of Airport Visual Aids Facilities*, for instructions on safety precautions.
- observe all safety regulations. To avoid injuries, always remove power prior to making any wire connections and touching any parts. Refer to FAA Advisory Circular AC 150/5340-26.
- read and become familiar with the general safety instructions provided in this section of the manual before installing, operating, maintaining, or repairing this equipment.
- read and carefully follow the instructions given throughout this manual for performing specific tasks and working with specific equipment.
- store this manual within easy reach of personnel installing, operating, maintaining, or repairing this equipment.
- follow all applicable safety procedures required by your company, industry standards, and government or other regulatory agencies.
- obtain and read Material Safety Data Sheets (MSDS) for all materials used.

Safety Symbols

Become familiar with the safety symbols presented in this section. These symbols will alert you to safety hazards and conditions that may result in personal injury, death, or property and equipment damage.



WARNING: Failure to observe this warning may result in personal injury, death, or equipment damage.



WARNING: Risk of electrical shock. Failure to observe this warning may result in personal injury, death, or equipment damage.

Safety Symbols (*contd.*)

WARNING: Disconnect equipment from line voltage. Failure to observe this warning may result in personal injury, death, or equipment damage.



WARNING: Wear safety goggles. Failure to observe may result in serious injury.



CAUTION: Failure to observe may result in equipment damage.

Qualified Personnel

The term *qualified personnel* is defined here as individuals who thoroughly understand the equipment and its safe operation, maintenance, and repair. Qualified personnel are physically capable of performing the required tasks, familiar with all relevant safety rules and regulations and have been trained to safely install, operate, maintain, and repair the equipment. It is the responsibility of the company operating this equipment to see that its personnel meet these requirements.

Intended Use

WARNING: Use of this equipment in ways other than described in this manual may result in personal injury, death, or property and equipment damage. Use this equipment only as described in this manual.

Siemens Airfield Solutions cannot be responsible for injuries or damages resulting from nonstandard, unintended applications of its equipment. This equipment is designed and intended only for the purpose described in this manual. Uses not described in this manual are considered unintended uses and may result in serious personal injury, death, or property damage. Unintended uses may result from taking the following actions:

- making changes to equipment that have not been recommended or described in this manual or using parts that are not genuine Siemens Airfield Solutions replacement parts
- failing to make sure that auxiliary equipment complies with approval agency requirements, local codes, and all applicable safety standards
- using materials or auxiliary equipment that are inappropriate or incompatible with your Siemens Airfield Solutions equipment
- allowing unqualified personnel to perform any task

Installation

Read the installation section of all system component manuals before installing your equipment. A thorough understanding of system components and their requirements will help you install the system safely and efficiently.



WARNING: Failure to follow these safety procedures can result in personal injury or death.

- Allow only qualified personnel to install Siemens Airfield Solutions and auxiliary equipment. Use only approved equipment. Using unapproved equipment in an approved system may void agency approvals.
- Make sure all equipment is rated and approved for the environment in which you are using it.
- Follow all instructions for installing components and accessories.
- Install all electrical connections to local code.
- Use only electrical wire of sufficient gauge and insulation to handle the rated current demand. All wiring must meet local codes.
- Route electrical wiring along a protected path. Make sure they will not be damaged by moving equipment.
- Protect components from damage, wear, and harsh environment conditions.
- Allow ample room for maintenance, panel accessibility, and cover removal.
- Protect equipment with safety devices as specified by applicable safety regulations.
- If safety devices must be removed for installation, install them immediately after the work is completed and check them for proper functioning.

Operation

Only qualified personnel, physically capable of operating the equipment and with no impairments in their judgment or reaction times, should operate this equipment.

Read all system component manuals before operating this equipment. A thorough understanding of system components and their operation will help you operate the system safely and efficiently.

Operation *(contd.)*

- Before starting this equipment, check all safety interlocks, fire-detection systems, and protective devices such as panels and covers. Make sure all devices are fully functional. Do not operate the system if these devices are not working properly. Do not deactivate or bypass automatic safety interlocks or locked-out electrical disconnects or pneumatic valves.
- Never operate equipment with a known malfunction.
- Do not attempt to operate or service electrical equipment if standing water is present.
- Use this equipment only in the environments for which it is rated. Do not operate this equipment in humid, flammable, or explosive environments unless it has been rated for safe operation in these environments.
- Never touch exposed electrical connections on equipment while the power is ON.

Action in the Event of a System or Component Malfunction

Do not operate a system that contains malfunctioning components. If a component malfunctions, turn the system OFF immediately.

- Disconnect and lock out electrical power.
- Allow only qualified personnel to make repairs. Repair or replace the malfunctioning component according to instructions provided in its manual.

Maintenance and Repair

Allow only qualified personnel to perform maintenance, troubleshooting, and repair tasks. Only persons who are properly trained and familiar with Siemens Airfield Solutions equipment are permitted to service this equipment.

- Always use safety devices when working on this equipment.
- Follow the recommended maintenance procedures in your equipment manuals.
- Do not service or adjust any equipment unless another person trained in first aid and CPR is present.
- Connect all disconnected equipment ground cables and wires after servicing equipment. Ground all conductive equipment.
- Use only approved Siemens Airfield Solutions replacement parts. Using unapproved parts or making unapproved modifications to equipment may void agency approvals and create safety hazards.

Maintenance and Repair*(contd.)*

- Check interlock systems periodically to ensure their effectiveness.
- Do not attempt to service electrical equipment if standing water is present. Use caution when servicing electrical equipment in a high-humidity environment.
- Use tools with insulated handles when working with electrical equipment.

2. Description

This section describes the Siemens Airfield Solutions L-852 series dualite taxiway inset light fixtures referred to in Table 1.

Table 1. L-852 Series Light Fixtures

L-852 Type	Function
L-852A	Used on taxiway centerline straight sections and clearance bar with a runway visual range (RVR) of ≥ 1200
L-852B	Used on taxiway centerline curved sections with an RVR of ≥ 1200
L-852C	Used on taxiway centerline straight sections and clearance bar with an RVR of ≤ 1200
L-852D	Used on taxiway centerline curved sections with and RVR of ≤ 1200

2. Description *(contd.)*

See Figure 1. The L-852A-D light fixtures are switchable lights designed to provide visual guidance along the taxiway centerline and is manufactured in accordance with FAA specification AC 150/5345-46A.

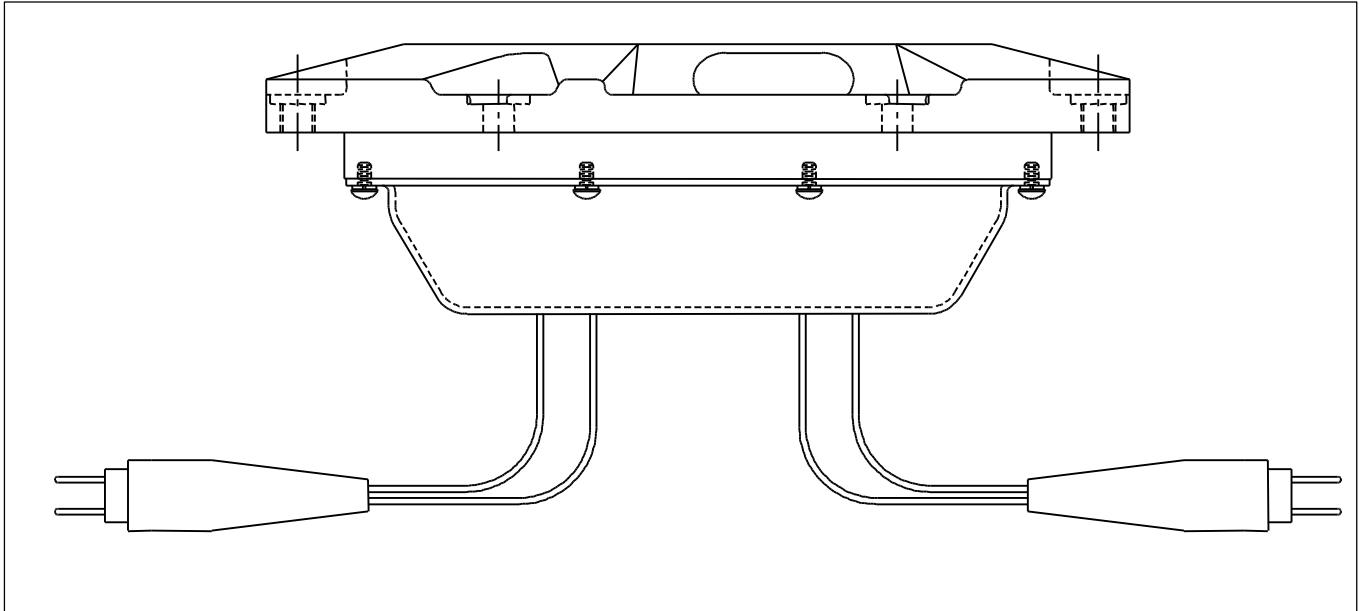

Figure 1. L-852A-D Dualite Light Fixture

Optical Assembly

See Figure 2. The L-852 series light fixture optical assembly consists of one or two 30 or 45-watt/6.6 A lamps, prisms, and color filters. Green and yellow filters are available for use in narrow beam for the L-852A and L-852C fixtures, and wide beam in the L-852B and L-852D fixtures. Blanked fixtures are used for unidirectional lighting.

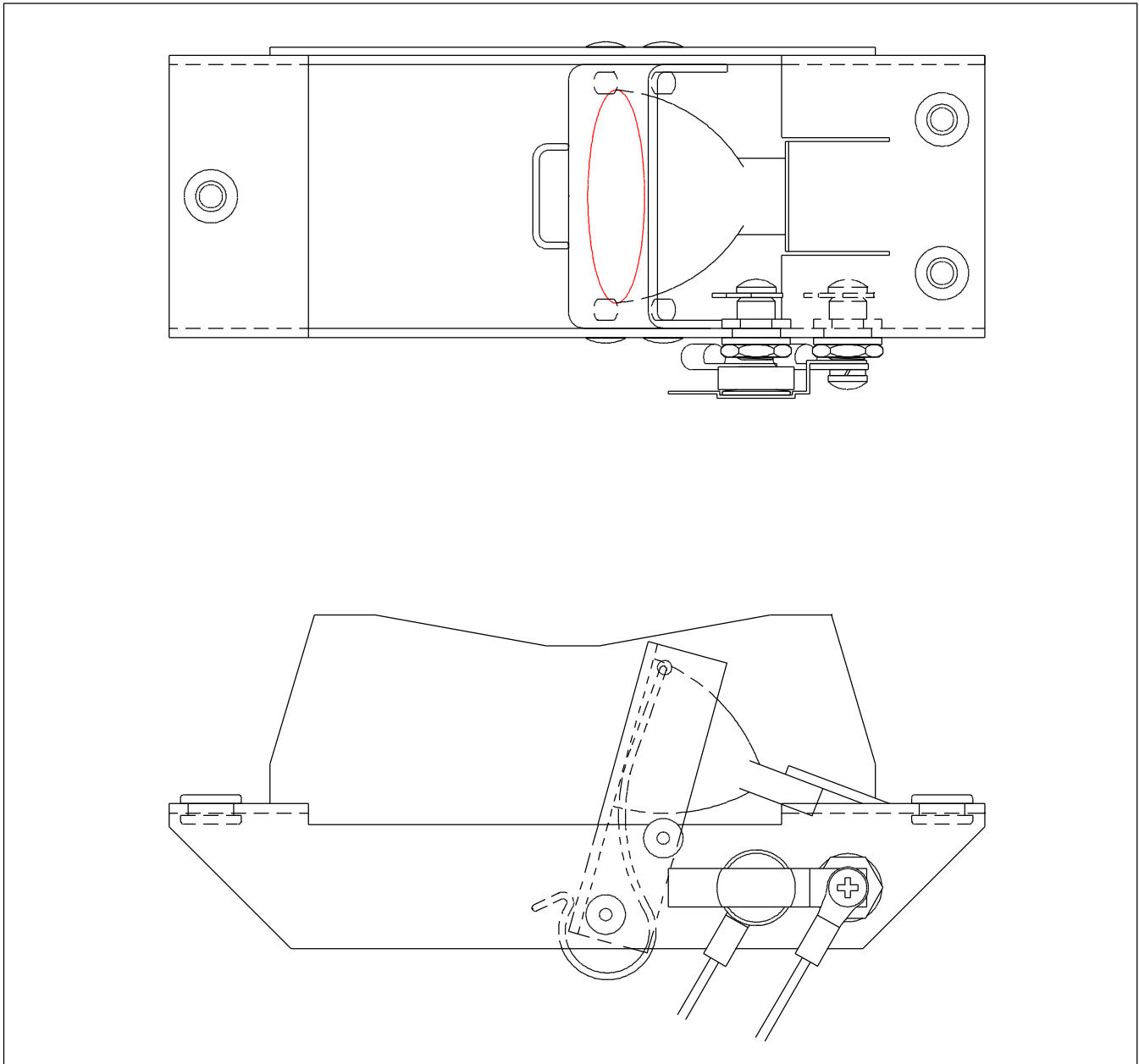

Figure 2. Optical Assembly

Optional Film Disc Cutout

In case of lamp failure, an optional film disc cutout is available as an electrical bypass device. The film disc cutout closes an auxiliary circuit around the lamp within 15 seconds after lamp failure. This prevents all lights from going out when several lights are run from a single transformer. The film disc cutout must be replaced when the lamp is replaced.



CAUTION: Do not use a film disc cutout with voltage driven lights. Transformer may be damaged.

**L-852A-D Light Fixture:
Required Equipment**

Refer to Table 2 for required equipment that is supplied. Refer to Table 3 for required equipment that is not supplied. Refer to the *Parts* section for part numbers.

Table 2. Required Equipment Supplied

Description	Quantity
L-852A- D inset light, with lamp(s)	1
Instruction manual	1

Table 3. Required Equipment Not Supplied

Description	Quantity
Torque wrench (0 to 200 in-lb) (0–22.6 Nt-M)	1
Alignment jig	1
Diamond-faced core drill, 13 in. (330 mm diameter)	1
Diamond-faced saw, 3/8 in. (9.525 mm) thick	1
Crimping tool	1
Small water suction pump	1
L-830 isolation transformer	1 or 2
Eyebolt, 3/8 in. (9.525 mm) diameter	2
Lifting rod, 16 in. (406 mm) long	1
Set of fiber brushes	1
Set of socket wrenches, 1/2 in. (12.7 mm) drive	1
Set of screwdrivers, one with 3/8 in. (9.525 mm) minimum blade width	1
Silicone grease	As required
Joint sealing filler	As required

Specifications

This subsection provides specifications for the L-852A-D light fixtures.

Lamps

Refer to the table below for lamps.

Number of Lamps	Lamp Wattage (W)	Lamp Current	Unit	Supplied with Fixture
One	45	6.6 A	Unidirectional	Yes
Two	45	6.6 A	Bidirectional	Yes
One	30	6.6 A	Unidirectional	Yes
Two	30	6.6 A	Bidirectional	Yes

Isolation Transformers

Refer to Table 4 for required isolation transformers.

Table 4. Required Isolation Transformers

Lamps	Series Circuit	Isolation Transformer	Watts	Amperes
30 & 45 W Unidirectional	6.6 A	L-830-1	45	6.6/6.6
30 & 45 W Unidirectional	20 A	L-830-2	45	20/6.6
30 W Bidirectional	6.6 A	L-830-3	65 W	6.6/6.6
45 W Bidirectional	6.6 A	L-830-4	100	6.6/6.6
30 & 45 W Bidirectional	20 A	L-830-5	100	20/6.6

Rated Lamp Life

2000 hours

Filter Colors

Green and yellow

Light Beam

Standard: 180 degrees bidirectional

Optional: switchable light direction

Mounting

The L-852A-D light fixtures mount on an optional Siemens Airfield Solutions shallow base or on a 12-inch- (304.8-mm-) diameter deep L-868B light base. Refer to Table 5 for connectors supplied.

Table 5. Connectors Supplied

If you order this...	This connector is supplied...
L-852A-D fixture with shallow base	Main lead assembly
L-852A-D fixture without shallow base	L-823 connector

Environmental Operating Conditions

The L-852A-D light fixture is designed to operate under the conditions presented below for temperature, altitude, and relative humidity.

Temperature

-55 to + 55 °C (-67 to +131 °F)

Altitude

Sea level to 10,000 feet (3050 m)

Relative Humidity

Up to 100 %

Dimensions

Height: 3.8 in. (96.25 mm)
 Diameter: 11.94 in. (303.28 mm)
 Bolt-circle diameter: 11.25 in. (285.75 mm)

Weight

25 lb. (11.34 kg) (approximate)

3. Installation



WARNING: Allow only qualified personnel to perform the following tasks. Observe and follow the safety instructions in this document and all other related documentation.

Introduction

This section provides instructions for installing the L-852A-D runway inset lights. Refer to airport project plans and specifications for the specific installation instructions. The installation shall conform to the applicable sections of the National Electric Code and local codes.

Unpacking

Each unit is individually packaged in a durable, cushioned, corrugated cardboard carton. To avoid unnecessary damage to the light assembly, unpack the carton at the installation site.

To unpack the carton, open the flaps and carefully remove the top packing material. Thread an eyebolt into each of the two opposite threaded holes. Run a rod through the eyebolts and lift the light assembly from the shipping carton. Set the light assembly in a protected area.

If damage to any equipment is noted, file a claim form with the carrier immediately. The carrier may request to inspect the equipment.

Input Requirement Summary

The L-852A-D is designed for connection to a 6.6 A or 20 A series lighting circuit via an L-830 isolation transformer. Refer to Table 3.

Installation Procedure

Installing the L-852A-D light fixture involves preparing the pavement recess and wireways and installing the light fixture on an L-868B base. Install the L-852A-D light fixture on a shallow base, if applicable.

Pavement Recess and Wireways Preparation

To prepare the pavement recess and wireways, follow the guidelines below.

- See Figure 3. Drill the recess in the pavement. For the L-852A-D dualite fixture, drill the hole a minimum of 4.5 in. (104.3 mm) deep.

Pavement Recess and Wireways Preparation (contd.)

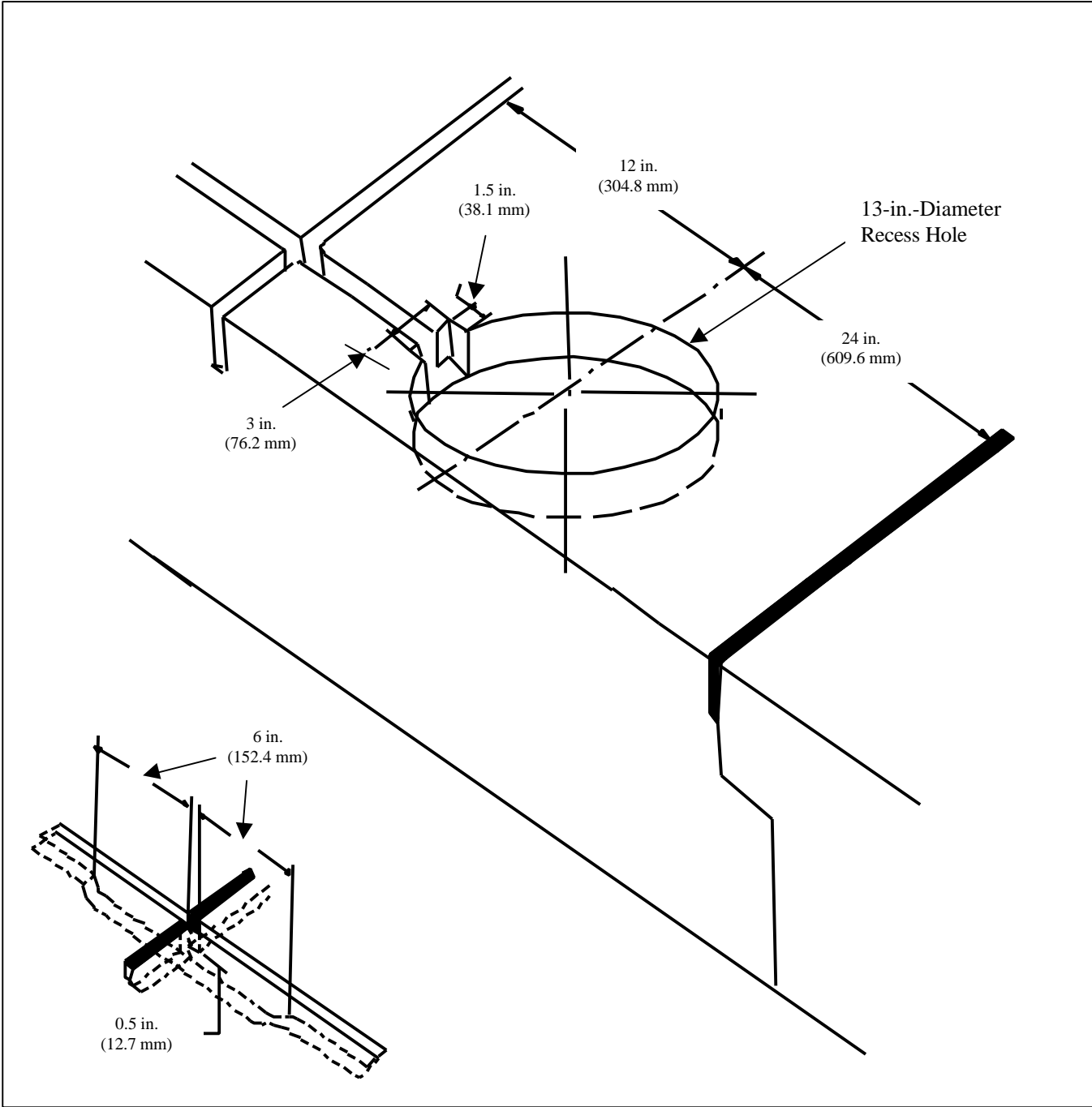

Figure 3. Preparing Pavement Recess and Wireways

Pavement Recess and Wireways Preparation (contd.)

- Make sure the recess size and depth are maintained within specified limits.
- The recess side walls must be perpendicular to the pavement surface.
- The bottom surface must be flat or slightly concave to ensure that the base receptacle is resting securely and in true position.
- The recess can best be drilled using a 13-in.- (330-mm-) diameter diamond-faced core drill in a sturdy, stable drill rig.

Wireways Preparation

To prepare wireways, follow the guidelines below.

- See Figure 3. The wireways should be sawed using a 3/8-in.- (9.525-mm-) thick diamond-faced saw.
- When the wireways cross construction joints, the sawcuts should extend 1-1/4-in. (31.75 mm) below the existing joint for a distance of 6 in. (152.4 mm) on each side of the joint.
- Fill to 1 in. (25.4 mm) from the top of the pavement with an appropriate joint sealing filler in accordance with Item P-605 or P-606 of FAA publication *Standard Specifications for Construction of Airports*. Item P-605 should be used with asphalt, and Item P-606 with concrete.

Installation on L-868B Base

The light assembly is shipped complete, including the lamp, and is ready for installation.

To install the L-852A-D light fixture on the L-868B base, perform the following procedure:

1. Clean the base receptacle. Make sure that the base receptacle does not contain water and is completely clean and dry. The mating surfaces must be clean and free of foreign particles.
2. Slide a 16-inch- (406-mm-) long rod through the 3/8-inch- (9.525-mm-) diameter eyebolts and carry the light assembly to the base. Align the light assembly with the runway for proper light direction.
3. Place the light assembly beside the opening in the L-868B base so that the L-823 connector can be connected with the mating receptacle from the L-830 isolation transformer in the base. Make sure that the

connection is solid and secure. Refer to Table 4 in *Specifications* in the *Description* section for required isolation transformers.

Installation on L-868B Base*(contd.)*

4. Turn on the power. Operate the light assembly for a minimum of five minutes. Turn off the power and allow the light assembly to cool.
5. Position the light assembly over the L-868B base and set onto the base. Align the light to the runway centerline. Make sure all spaces, shims, and gaskets are in place before installing light fixture on the base. Remove the eyebolts and lifting rod.
6. Turn on the power to check that the lamp will illuminate. Operate for a minimum of five minutes.



CAUTION: The light assembly will be hot after this test. Allow time for assembly to cool before proceeding.

7. Apply one drop of Loctite AV to each of the six light assembly mounting bolts. Install the six bolts and lockwashers. Torque the bolts to 185 ± 5 inch-pounds (20.902 ± 0.565 Nt-M). Torque across the corners. Refer to *Retorquing Mounting Bolts* in the *Maintenance* section.

Installation on Siemens Airfield Solutions Shallow Base

To install the L-852A-D dualite light fixture on a Siemens Airfield Solutions shallow base, perform the following procedure:

1. Splice the light assembly leads to AWG 16 wires with suitable pre-insulated connectors, crimped with the proper tool.
2. Train the leads and AWG 16 wires carefully so they run along the bottom of the sawed wireways.

NOTE: Small wads of plastic insulating tape may be used to wedge the leads and cables in the bottom of the wireways if necessary. Refer to Table 4 for the appropriate isolation transformer required for installation between the fixture and the series lighting circuit.

3. Make sure the O-ring is seated in the O-ring groove before bolting the fixture to the shallow base.
4. Lightly sand blast and clean with solvent all external surfaces that will be bonded into the runway, except for the wire entrance seal. This is done to make sure an adequate bond between the shallow base and sealer exists.



CAUTION: Do not handle the light fixture by the leads. This can break the waterproof seal and cause electrical leakage.

**Installation on Siemens
Airfield Solutions Shallow
Base (contd.)**

5. See Figure 4. Use an alignment jig to align the light assembly. The jig has three positioning screws that fit into the tapped holes holding the light fixture to the shallow base.

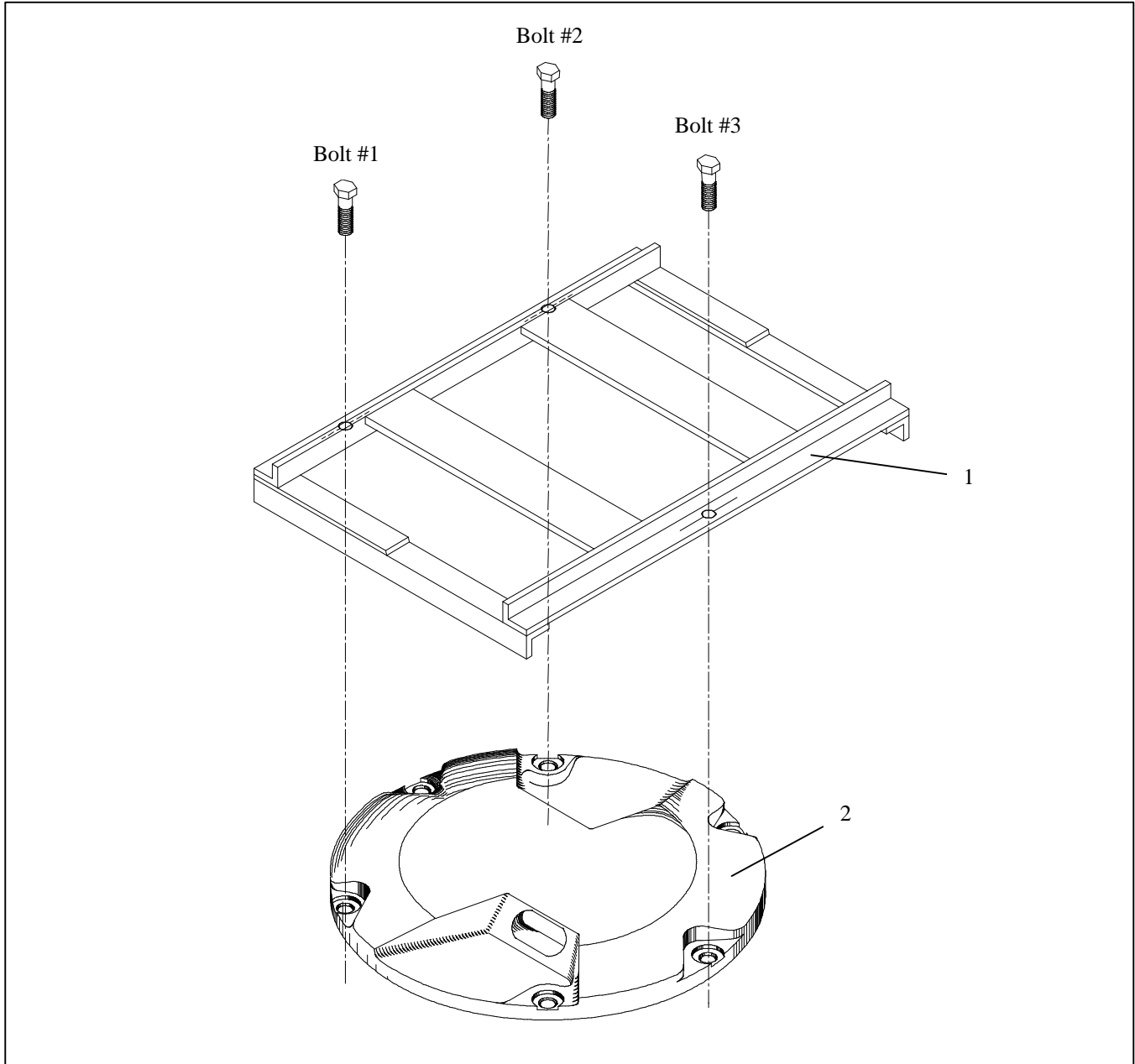

Figure 4. Alignment Jig

1. Jig
2. L-852A-D Light Fixture

**Installation on Siemens
Airfield Solutions Shallow
Base** (contd.)

6. To attach the alignment jig, remove bolts #1, 2, and 3 from the light fixture.
7. Secure the jig with the three screws provided with the fixture. Contact the Siemens Airfield Solutions Sales Department if further information is required concerning the jig.

NOTE: It may be necessary to place temporary plugs for blocking the wireway entrance into the drilled holes or recess. The plugs will retain the sealer during the setting of the light assembly.

8. Cover the bottom of the shallow base completely with a P-606 paste-type sealer. Place a sufficient quantity of P-606 paste material in the drilled hole to force material out when the base is inserted. This ensures a bond between the bottom of the shallow base and the drilled hole.

NOTE: When the base is placed in the recess, sealer material should be forced up the sides of the base at least 1/8 in. (3.175 mm).

NOTE: The jig is used to position the light assembly with arrows on the top of the fixture pointing along the taxiway centerline.

9. If necessary, place a weight on the jig to hold the light assembly in proper position.
10. Fill the remainder of the space between the sides of the base and the drilled recess with a liquid sealer to a level 3/4 in. (19 mm) below the pavement surface. The jig should be left in place until the sealer reaches its initial set.
11. If any voids are present around the shallow base after the initial set, they should be filled with P-606 paste and all excess sealer removed. Remove the jig for complete visibility of voids.
12. Fill the top 3/4 in. (19 mm) gap between the fixture and pavement with flexible sealing material to minimize water penetration and pavement deterioration.
13. Apply grade AV Loctite to the bolt threads, and reinstall the three bolts and lockwashers. Torque bolts to 185 ±5 in-lb (20.9 ±.6 N-m).
14. Fill the wireways completely with a polyester compound and let it cure at least 24 hours before disturbing, unless otherwise specified. Refer to AC 150/5345-4C for construction and sealing instructions for wireways.

4. Maintenance

This section provides maintenance information and procedures for the L-852A-D light fixture.

Maintenance Schedule

Service life depends upon the entire assembly being waterproof. All surfaces must be clean, dry and free of all foreign matter and all bolts must be properly tightened if the light fixture is to operate for extended periods without requiring maintenance.

To keep the L-852A-D light fixtures operating efficiently, follow a preventive maintenance schedule. Refer to Table 6. Refer to FAA AC 150/5340-26 for more detailed information.

Table 6. L-852A-D Light Fixture Maintenance

Interval	Maintenance Task	Action
Daily	Check for burned-out lamp. Check for dim lamp.	Replace lamp and film disc cutout, if used. Refer to <i>Replacing Lamp</i> in this section. Clean optical surface if dirty. Check for misalignment or presence of moisture in fixture.
Weekly	Check for dirty channel and prism.	Clean channel and prism. Refer to <i>Cleaning Light Channel and Prism</i> in this section.
Monthly (or more frequently during rainy seasons)	Check for moisture in the light fixture.	Open up the light fixture. Clean, dry, and inspect the light assembly. Replace O-ring.
Every 60 days, or whenever the light assembly is serviced	Check for improper torque on holddown bolts.	Torque six bolts holding fixture to base to base receptacle to 185 ± 5 in-lb (20.902 ± 0.565 Nt-M). Use Loctite to keep bolts tight. Refer to <i>Retorquing Mounting Bolts</i> in this section.
Semi-annually	Check for six inches (152 mm) of water in L-868B base.	Pump water from base. Remove and inspect light for water damage. Refer to <i>Removing L-868B Base Water</i> in this section.
After 1600 hours operation	Not applicable	Replace lamp Refer to <i>Replacing Lamp</i> in this section.
After snow removal	Check for damaged light fixtures.	Replace damaged fixtures. Use a power broom for snow removal, if practical. Follow recommended snow removal techniques described in AC 150/5200-23.

Maintenance Procedures

This subsection describes the following maintenance procedures:

- replacing lamp
- cleaning light channel and prism
- retorquing mounting bolts
- removing L-868B base water

Replacing Lamp



WARNING: Turn off the circuit before replacing lamp(s). Failure to observe this warning may result in personal injury, death, or equipment damage.



WARNING: Allow time for the unit to cool. High interior temperatures may cause severe burns to personnel. Failure to observe this warning may result in personal injury.

The preferred method of maintaining the L-852A-D inset light is to periodically and systematically replace the light assembly and return the replaced assembly to the maintenance shop for renovation. As an alternative, you can service the light assembly in the field. It is recommended, however, that field servicing be limited to cleaning lenses and replacing lamp(s).

NOTE: It is recommended that you replace the lamp after 80% (1600 hours) of its useful life.

NOTE: If any lamps are out, record the location of the fixture and replace the lamp when the circuit is turned off.

Refer to *Replacing Lamp* in the *Repair* section for lamp replacement procedure.

Cleaning Light Channel and Prism

To clean the light channel and prism, perform the following procedure:

1. See Figure 5. Use a suitable fiber brush to remove all accumulated debris from the light channel (7).

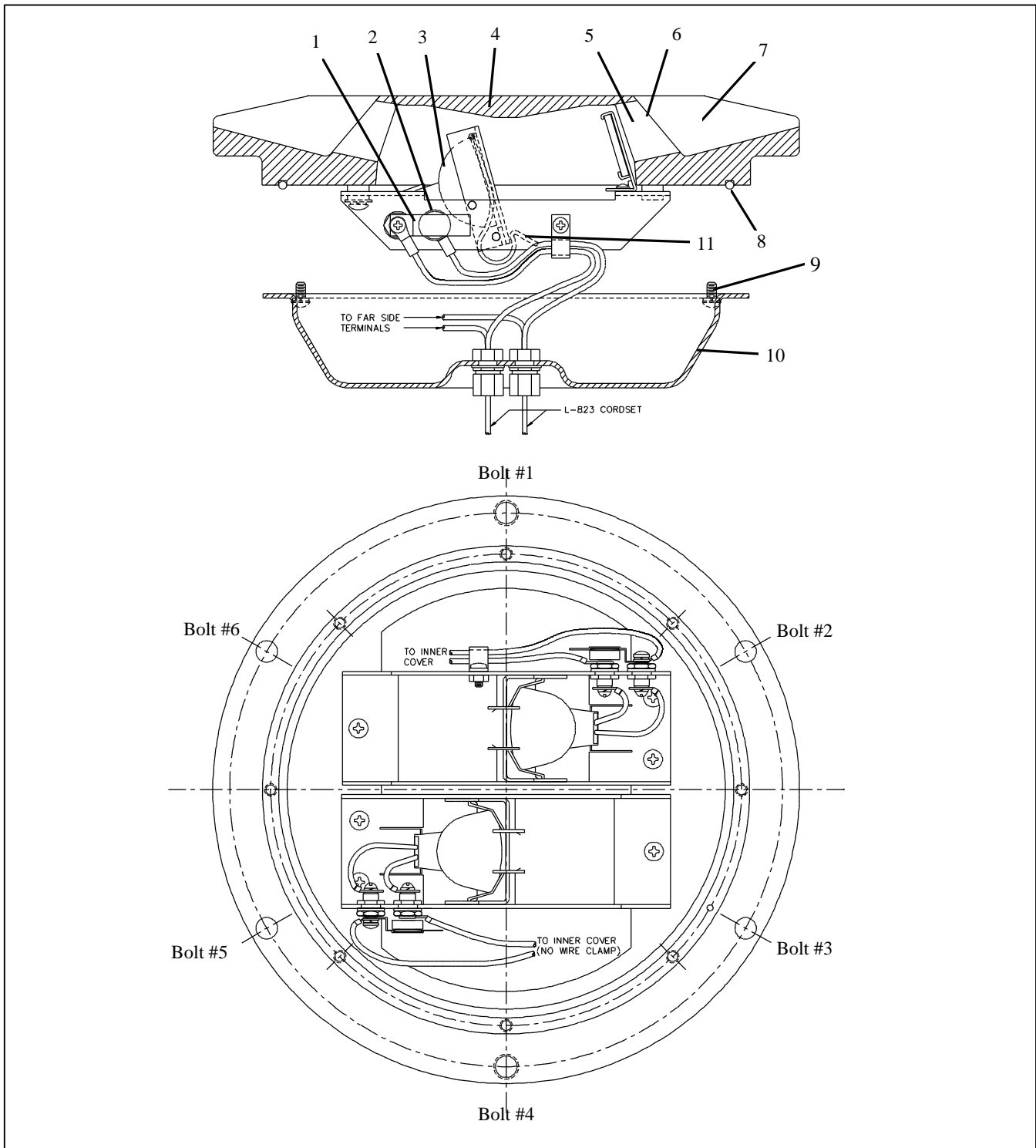

Figure 5. Cutaway View of Optical Assembly

- | | | |
|-------------------------------|------------------------|--------------------------|
| 1. Cutout Clip | 5. Prism | 9. Pan Head Screws |
| 2. Disc Cutouts | 6. Prism Outer Surface | 10. Inner Cover Assembly |
| 3. Lamp Assembly | 7. Light Channel | 11. Spring Clip |
| 4. Top (Outer) Cover Assembly | 8. O-ring | |

Cleaning Light Channel and Prism *(contd.)*

2. Clean the outer surface of the prism (6) using liquid glass cleaner. If the prism is coated with a substance impervious to the cleaner, apply a suitable solvent sparingly with a wad of cotton or a patch of cloth. After the solvent has acted, remove the softened coating with a clean piece of cotton or cloth. Dry the prism with gently, dry, oil-free compressed air at a pressure no greater than 10 psi (69 kNt/m²) to evaporate or remove all remaining cleaner.

Retorquing Mounting Bolts

When retorquing mounting bolts, apply one drop of Grade AV Loctite to each of the six 3.8-inch- (9.525-mm-) diameter mounting bolts. Torque the bolts to 185 ±5 inch-pounds (20.902 ± 0.565 Nt-m). Torque the bolts across the corners.

See Figure 3. To torque the outer bolts across corners, tighten bolts in noted sequence: #1 and #4, then #2 and #5, then #3 and #6.

NOTE: Applying more than one drop of Loctite to the screw and bolt threads will create future difficulty in removal of the bolts.

NOTE: After several relampings, threaded holes may accumulate with dirt and excessive Loctite. If this occurs, screws may not seat properly. Clean holes with light weight oil or diesel fuel using a small fiber brush. Wipe the holes clean with alcohol to remove all oil or diesel fuel and dirt. Clean with dry, oil-free, low-pressure air.

Removing L-868B Base Water



Turn off the circuit when checking water level.

Check the water level in the L-868B base on a regular schedule. If more than six inches (152.4 mm) of water in the light base is found, pump the water from the base and remove and inspect the entire light assembly for water damage. Cover the L-868B base with the appropriate steel cover plate after removing the light assembly.



Water does enter the L-868B base. This can become a serious problem, since freezing water can rupture the base.

5. Troubleshooting



WARNING: Allow only qualified personnel to perform the following tasks. Observe and follow the safety instructions in this document and all other related documentation.



WARNING: De-energize the circuit and lock out the circuit or regulator so that the circuit cannot be energized by remote means before attempting to service the fixture.

This section contains troubleshooting information. This information covers only the most common problems that you may encounter. If you cannot solve the problem with the information given here, contact your local Siemens Airfield Solutions representative for help.

Problem	Possible Cause	Corrective Action
1. Lamp will not energize	Defective lamp	Replace lamp and film disc cutout (if used). Refer to <i>Replacing Lamp</i> in the <i>Maintenance</i> section.
	Loose or broken contacts	Tighten or replace.
	Moisture inside assembly causing current leakage	Open up light assembly. Clean, dry, and inspect light assembly. Replace O-ring.
	Defective isolation transformer	Check transformer output current with meter.
2. Lamp not turning on at normal level	Continuity incorrect	Check lamp filament and wiring for continuity.
3. Lamp output distorted	Broken or damaged prism	Replace outer cover assembly.
4. Improper color	Filter broken	Replace filter bracket assembly.
	Filter bracket broken	Replace filter bracket assembly.

Continued on next page

5. Troubleshooting *(contd.)*

Problem	Possible Cause	Corrective Action
5. Short lamp life	Current too high	Check constant current regulator and isolation transformer.
	Water in assembly	Inspect prism. Open light assembly. Clean, dry and inspect light assembly. Replace O-ring.
	Defective lamp	Replace lamp and film disc cutout (if used). Refer to <i>Replacing Lamp</i> in the <i>Maintenance</i> section. NOTE: Lamp interior will have a white powdery appearance if air has entered through a hole or crack.
	Overvoltage	Check to see if lamp has black burns. If so, check isolation transformer output with meter. Replace isolation transformer, if defective.
6. Distorted light beam output in L-852A-D	Filter/spreader installed wrong	Reinstall the filter/spreader with the smooth flat side of the filter toward the lamp.

6. Repair

This section describes procedures for repairing and replacing parts. It includes replacing the film disc cutout assembly, the lamp, and prism.

Replacing Film Disc Cutout Assembly

To replace the film disc cutout assembly, perform the following procedure:

1. Remove eight screws from bottom cover assembly.
2. Remove and inspect o-ring. Discard if damaged, affected by compression set or no longer fits in groove.
3. Remove and replace cordsets and film disc cutout hardware as required using Figure 6 as a guide.

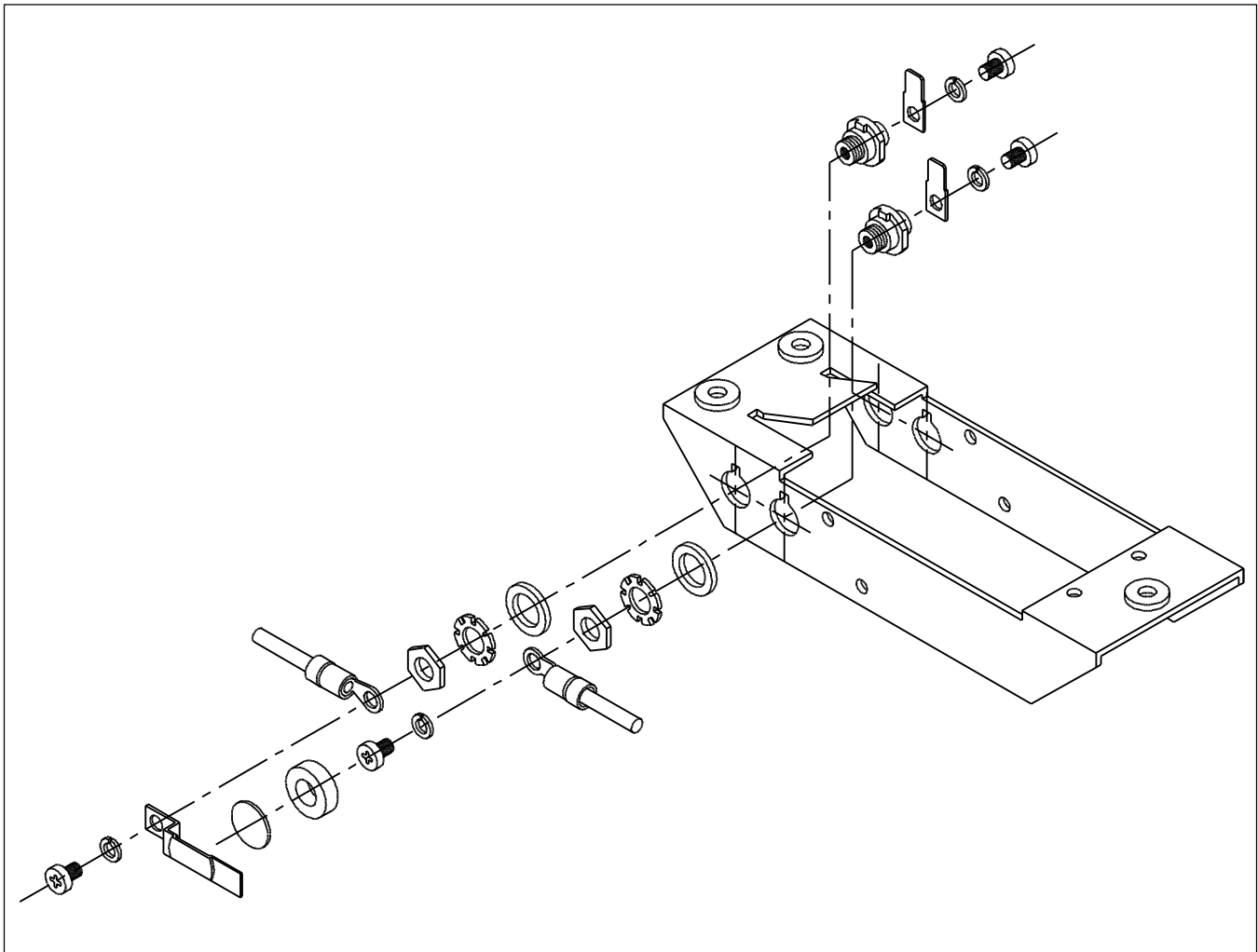

Figure 6. Replacing Film Disc Cutout Assembly

4. Install new or existing o-ring from Step 4. Coat o-ring with silicone grease before installing.
5. Place bottom cover assembly in place and pull out majority of cordset slack.

NOTE: Leave enough cordset slack so that the pan can be opened.

6. Move bottom cover as required to check for lamp access for future lamp changes.
7. Permanently attach bottom cover with eight screws. Torque to 25 in-lb.

Replacing Lamp



WARNING: Turn off the circuit before replacing lamp(s). Failure to observe this warning may result in personal injury, death, or equipment damage.



WARNING: Allow time for the unit to cool. High interior temperatures may cause severe burns to personnel. Failure to observe this warning may

To replace lamp, perform the following procedure:

1. Remove the six 3/8-inch- (9.525-mm-) diameter bolts that hold the light fixture on the base receptacle.
2. Install two 3/8-inch- (9.525-mm-) diameter eyebolts in two holes (180 degrees apart) on the fixture and insert a 16-inch- (406-mm-) long steel rod through eyebolts and lift the fixture out of the base receptacle.
3. See Figure 5. Turn the fixture upside down and remove the eight pan-head screws (9) holding the inner cover to the top cover assembly.

NOTE: The inner cover assembly (10) can now be separated from the top outer cover assembly (4). The inner cover assembly can now be moved from side to side to allow for lamp removal without having to adjust slack in the cordset.

4. Flip the holddown spring clip (11) off the lamp assembly (3), and pull the lamp assembly horizontally forward out of the socket.



CAUTION: The lamp assembly consists of a lamp and reflector. It is a single unit and is fragile. Handle with care. Failure to observe this warning could result in equipment damage.

5. Install the new lamp by reversing the lamp removal procedure.



CAUTION: Do not touch the quartz lamp inside the reflector with bare hands when handling the lamp assembly since this can reduce lamp life. If the lamp is touched, clean it with a lens cleaning tissue moistened with isopropyl alcohol.

Replacing Lamp (*contd.*)

6. Replace the film disc cutout (2) (if used) from the inner cover assembly. To remove the cutout, perform the following procedure:
 - a) Loosen the screw that secures the wire lead to the feed-thru, and rotate the cutout clip (1) free from the top of the cutout.
 - b) Position the new disc cutout (small button side down) on the head of the screw in the terminal post. Rotate the cutout clip on top of the disc, and hold in place while tightening the screw.

NOTE: Make sure the cutout clip has sufficient tension to hold the cutout disc tightly against the screw head. If the cutout is loose, remove the clip and bend slightly to increase tension.

7. Examine the O-ring (8) carefully. If the O-ring is stretched or torn, has a permanent set or other defect that would prevent it from forming a watertight seal, replace the seal. Coat the O-ring with silicone grease before installing. Carefully position the O-ring in the groove on the outer cover assembly and gently press into place.

NOTE: The groove is made wider than the O-ring to provide room for displacement of the O-ring when compressed between the housing when the screws on the inner cover assembly are properly torqued to 24 ± 5 inch-pounds (2.712 ± 0.565 Nt-M).

NOTE: If the o-ring is too large, replace o-ring.

8. Reinstall the eight pan-head screws that secure the inner cover assembly to the outer cover assembly. Torque screws across corners to 24 ± 5 inch-pounds (2.712 ± 0.565 Nt-M).
9. Reinstall the light fixture in the base receptacle using the six 3/8-inch- (9.525-mm-) diameter bolts. Coat bolt threads with a drop of Loctite Grade AV before installation and torque to 185 ± 5 inch-pounds (20.902 ± 0.565 Nt-M). Torque across corners. Refer to *Retorquing Mounting Bolts* in the *Maintenance* section.

NOTE: Applying more than one drop of Loctite to the screw and bolt threads will create future difficulty in removal of the bolts.

NOTE: After several relampings, threaded holes may accumulate with dirt and excessive Loctite. If this occurs, screws may not seat properly. Clean holes with light-weight oil or diesel fuel using a small fiber brush. Wipe clean with alcohol to remove all oil or diesel fuel and dirt. Clean with dry, oil-free, low-pressure air.

Replacing Prism

Replace the prism if it is broken or its surface is badly pitted or scarred. If you replace the prism, return the unit to Siemens Airfield Solutions for repair. Any attempt to replace the prism in the field prior to warranty expiration will terminate the warranty on the unit.

7. Parts

To order parts, call Siemens Airfield Solutions Customer Service or your local representative. Use this four-column parts list, and the accompanying illustration, to describe and locate parts correctly.

Using the Illustrated Parts List

The Item column numbers correspond to the numbers that identify parts in illustrations following each parts list. NS (not shown) indicates that a listed part is not illustrated.

The Description column gives the part name, as well as its dimensions and other characteristics when appropriate. Indentions show relationships between assemblies, subassemblies, and parts.

The Part Number column gives the Siemens Airfield Solutions part number.

Item	Description	Part Number	Note
NS	Assembly	XXXXXXXX	A
T1	Assembly Part Part	XXXXXXXX XXXXXXXX	

The Note column contains letters that refer to notes at the end of each parts list. Notes contain special ordering information.

L-852A-D Light Fixture Part Numbering System

Figure 7 shows how to determine the part number for a particular L-852A-D light fixture.

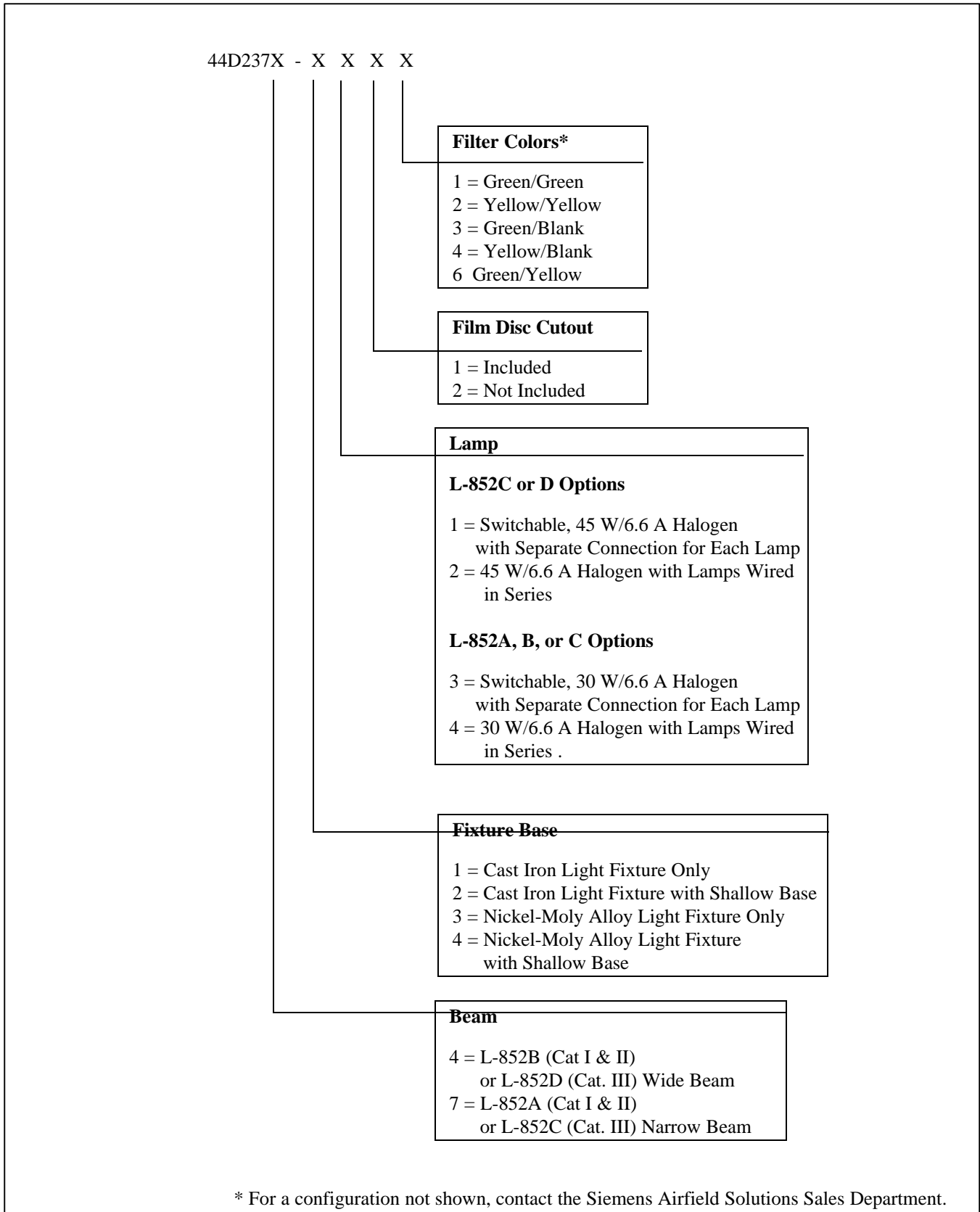

Figure 7. L-852A-D Light Fixture Part Numbers

**L-852A-D Light Fixture Parts
List**

See Figure 8.

Item	Description	Part Number	Note
1	Lamp assembly Lamp assembly, 45 W, 6.6 A (L-852C, L-852D) Lamp assembly, 30 W, 6.6 A (L-852A, L-852B, L-852C)	44B1605 44A4785	
2	Outer cover assembly Outer cover assembly, ductile iron Outer cover assembly, ductile iron with Ni-Mo alloy	44B2185-1 44B2185-2	
3	Filter assembly, red Filter, yellow, wide beam Filter, green, wide beam, L-852B, L-852D Filter, yellow, narrow beam, L-852A, L-852C Filter, green, narrow beam, L-852A, L-852C	44A4781-1 44A4781-3 44A4781-4 44A4781-6	
4	Optical assembly Optical assembly, without optical shield and film disc cutout Optical assembly, with optical shield and without film disc cutout Optical assembly, without optical shield and with film disc cutout Optical assembly, with optical shield and film disc cutout	44C2187-1 44C2187-2 44C2187-3 44C2187-4	
5	Cutout clip	60B0240	
6	Film disc cutout, GE #4815920 G-2	47A0023	
7	O-ring, silicone, Parker #2-270	63B0267-270	
8	Shallow base assembly Shallow base assembly with plywood cover Shallow base assembly only	44D0465-1 62D0335-1	
NS	Silicone grease	67A0009	
NS	Loctite Grade AV	67A0008	
NS: Not Shown			

L-852A-D Light Fixture Parts

List (contd.)

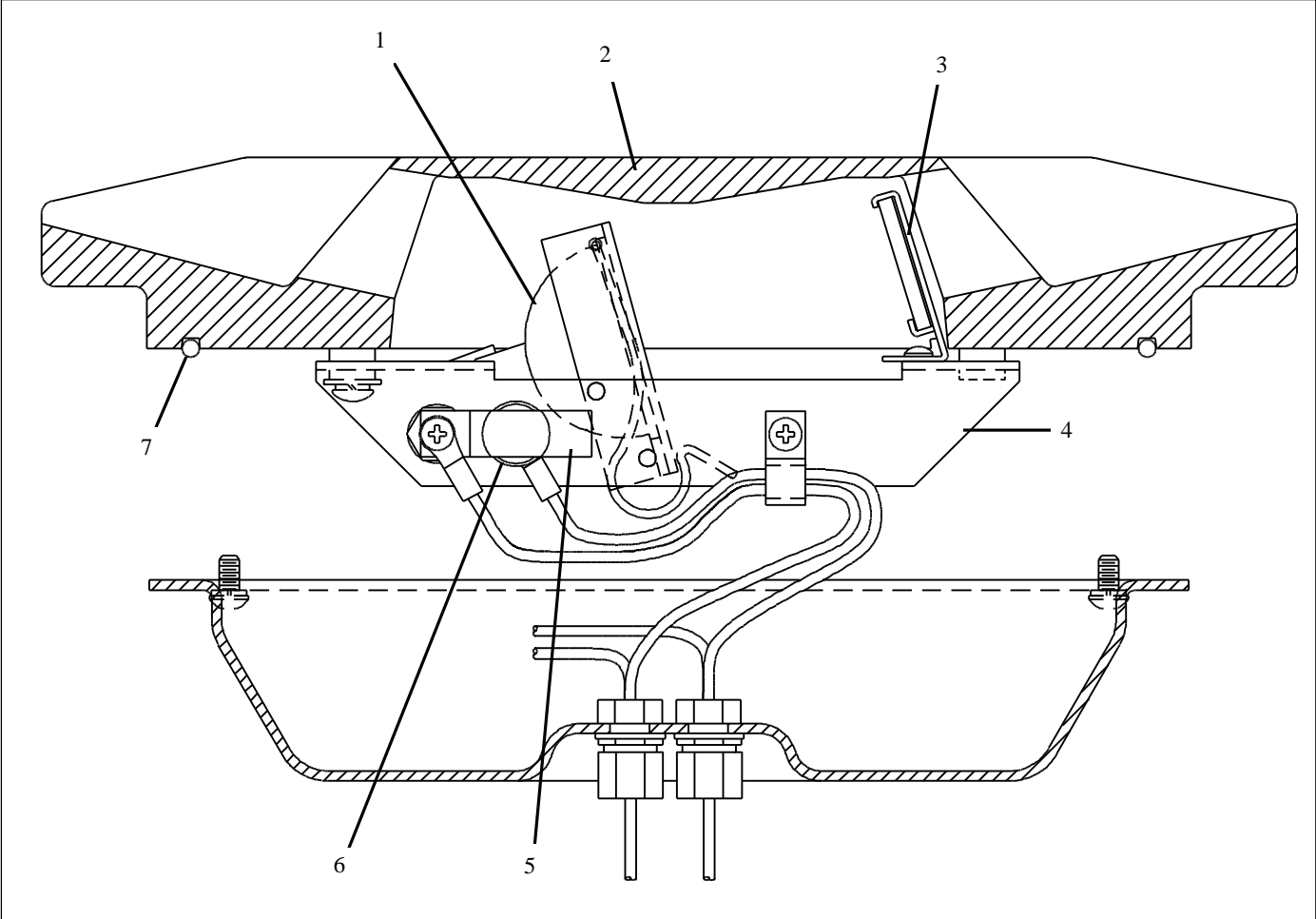

Figure 8. L-852A-D Light Fixture with Shallow Base (Part 1 of 2)

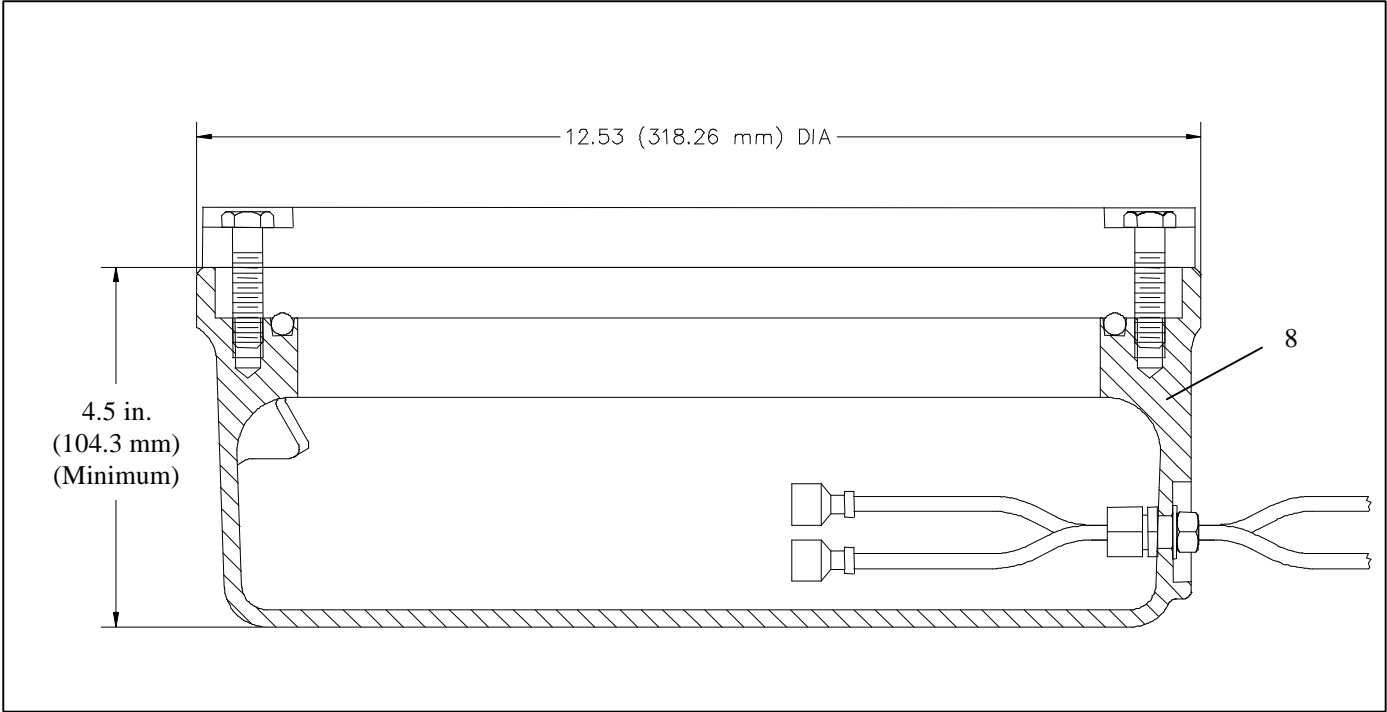

Figure 8. L-852A-D Light Fixture with Shallow Base (Part 2 of 2)

**Recommended Spare Parts
List**

See Figure 8.

Item	Description	Part Number	Note
1	Lamp assembly Lamp assembly, 45 W, 6.6 A (L-852C, L-852D) Lamp assembly, 30 W, 6.6 A (L-852A, L-852B, L-852C)	44B1605 44A4785	
6	Film disc cutout, GE 4815920 G-2	47A0023	
7	O-ring, silicone, Parker #2-270	63B0267-270	
NS	Silicone grease	67A0009	
NS: Not Shown			